

BZ33-PTACHP12-G2

ID# .3473459

COOL/HEAT PUMP



FEATURES

- Cools and heats a room up to 500 sq. ft.
- Easy washable filter
- Quiet operation
- Auto defrost
- Auto restart
- Fresh air ventilation
- Auxiliary mode selection
- 20A Power cord included
- Electronic control

12,000 BTU

Quickly cool and heat spaces up to 500 square feet.

QUIET OPERATION

The unit is constructed with a sturdy chassis to reduce vibration and sound transmission.

AUXILIARY MODE

Provides customization, better temperature control, and more functional detail.

ELECTRONIC CONTROL

Precisely control the temperature of the space by easily choosing the temperature setting or fan speed.

AUTO RESTART

In the event of a power failure, the unit will resume normal operation automatically when power returns.

WASHABLE FILTER

Keep the air as fresh as possible and remove residue build-up with an easily washable filter.

UNIT	ID NO.	MODEL
PTAC	.3473459	BZ33-PTACHP12-G2

PERFORMANCE - COOLING		208/230
Capacity	BTU/H	11,800 / 12,000
EER	BTU/H/W	10.5
Input	W	1,124 / 1,142
Current	A	5.4 / 5

PERFORMANCE - HEATING (PTC)		208/230
Capacity (3.4kW)	BTU/H	8,900 / 10,900
Input	W	2,900 / 3,535
Current	A	13.7 / 15.3
MCA		20

PERFORMANCE - HEATING (HEAT PUMP)		208/230
Capacity	BTU/H	10,500 / 10,800
Input	W	963 / 990
Current	A	4.6 / 4.3
COP	W/W	3.2

FEATURES

Cooling/Heating	Yes / Yes
Control Type	Electronic
Energy Saver	No
ENERGY STAR®	No
Auto Restart	Yes
Sleep Mode	No
Filter Monitor	No
Timer	No
Fan Speeds	3
Slide-out Chassis	Yes
Washable Filter	Yes
Warranty	Yes*

SPECIFICATIONS

Fresh Air Intake (Hi/Med/Lo)	CFM	62 / 60 / 56
Dehumidification	Pt/Day	61
Indoor Level (Hi/Med/Lo)	dBA	52 / 51.5 / 51
Outdoor Level (Hi)	dBA	67
Cooling Area	Sq. Ft.	450-500
Refrigerant		R410A or R32†

*1 year warranty on parts. 5 year warranty on compressor.

† Refrigerant dependent on model generation.

ELECTRICAL DATA

Power Supply	V/Hz/Ph	208-230 / 60 / 1
Plug Type		LCDI (6-20P)

DIMENSIONS

Product (W x D x H)	In	42 x 23-7/8 x 16
Shipping (W x D x H)	In	44-1/2 x 24-5/8 x 19-1/4
Net/Gross Weight	Lbs	116 / 125.4

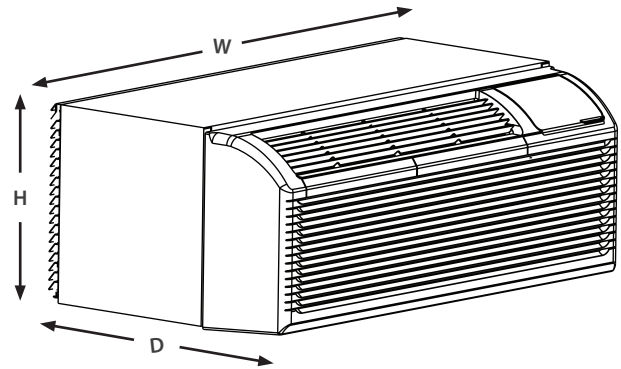

RECOMMENDED ACCESSORIES

BZ33-PTACWS .3473461

Description	Wall Sleeve, White
Dimensions (W x D x H)	In 42 x 14-3/4 x 16

BZ33-PTACGRILL1 .3514045

Description	Standard Grille, White
Dimensions (W x D x H)	In 41-5/8 x 3/8 x 15-5/8

BZ33-PTACGRILL2 .3473463

Description	Extruded Architectural Grille, Grey
Dimensions (W x D x H)	In 41-3/4 x 1 x 15-1/4

LCDI 6-20P

